

Installation instructions, accessories

Volvo Car Corporation Gothenburg, Sweden

Instruction No 31330604
Version 1.7
Part. No. 31414189, 31201481

Tire pressure monitoring system (TPMS)

Special tools

T9513035 TPMS tool

Tool number: T9513035

Tool description: TPMS tool

Tool boards:

Equipment

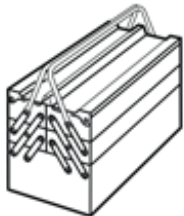

A0000162



Nm
lbf.ft

A0000161



A0801178

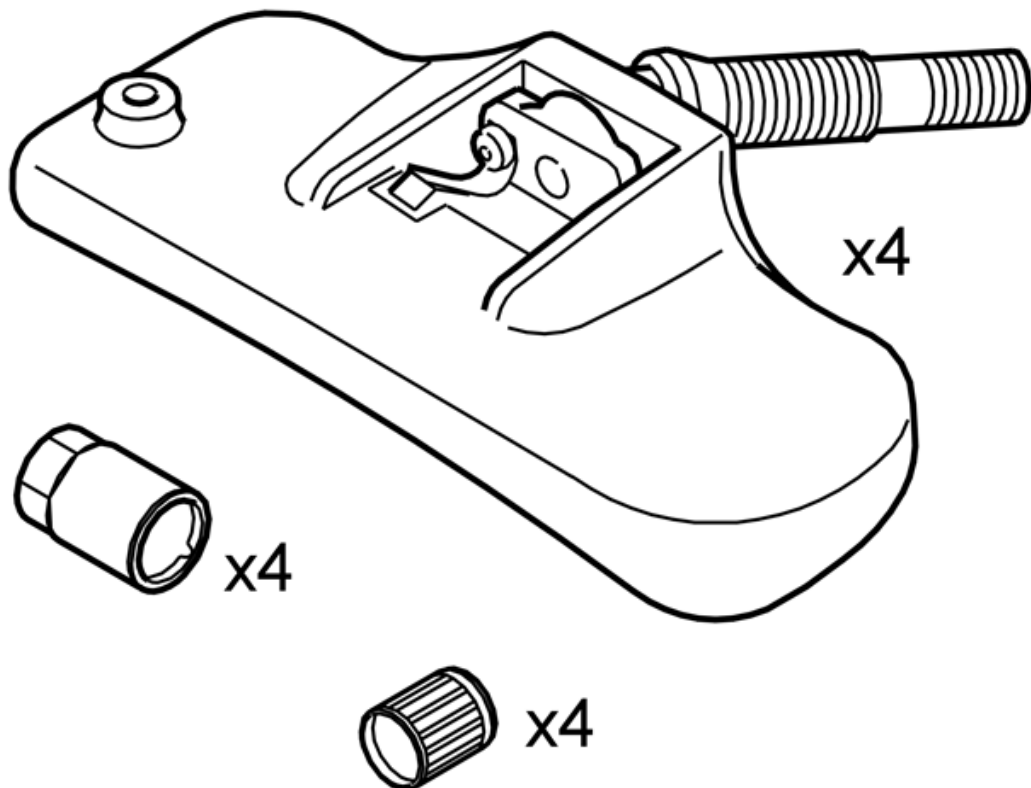

IMG-229180

Installation instructions, accessories

Volvo Car Corporation Gothenburg, Sweden

Installation instructions, accessories

Volvo Car Corporation Gothenburg, Sweden

INTRODUCTION

Read through all of the instructions before starting installation.

Notifications and warning texts are for your safety and to minimise the risk of something breaking during installation.

Ensure that all tools stated in the instructions are available before starting installation.

Certain steps in the instructions are only presented in the form of images. Explanatory text is also given for more complicated steps.

In the event of any problems with the instructions or the accessory, contact your local Volvo dealer.

Note!

This accessory requires software unique to the car.

Note!

Perform installation on all four wheels.

Note!

When installing tyre pressure sensor on complete wheel, the tyre must first be removed from the rim and then fitted as below.

Installing tyre pressure sensor on loose rim and tyre

Installation instructions, accessories

Volvo Car Corporation Gothenburg, Sweden

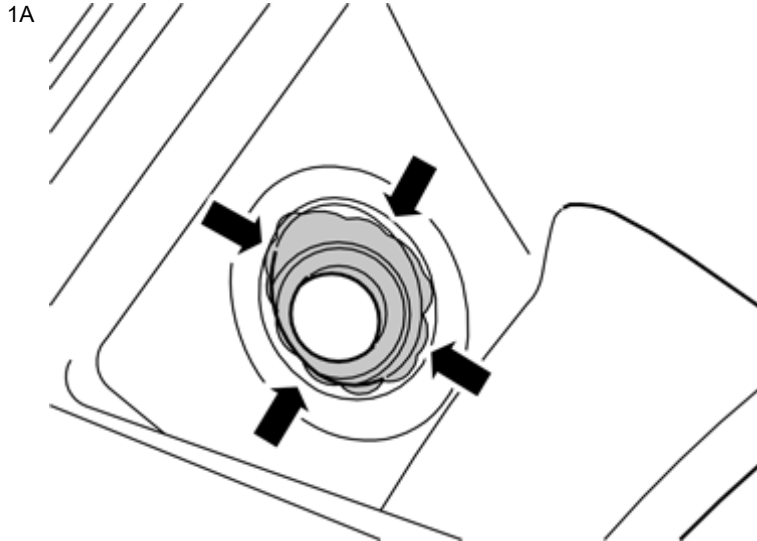

IMG-216861

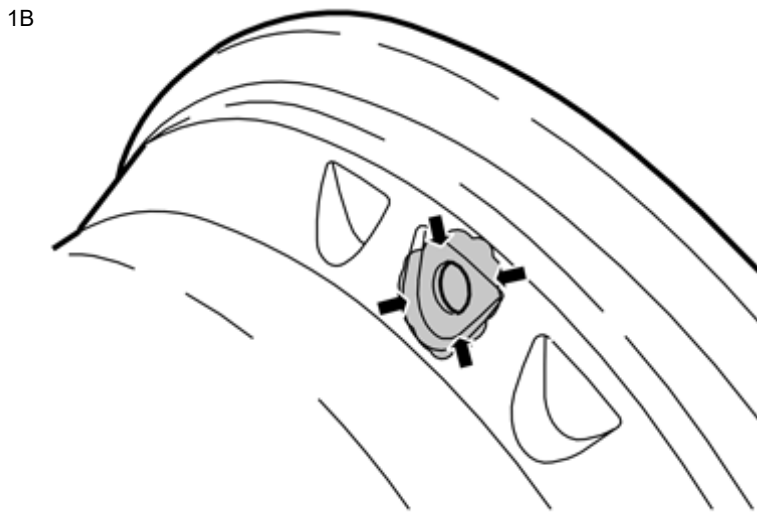

IMG-216862

Installing tyre pressure sensor on loose rim and tyre

Illustration A

Illustration B

Clean the inside and outside of the rim by the hole for the tyre valve. Also clean the inside of the hole edge.

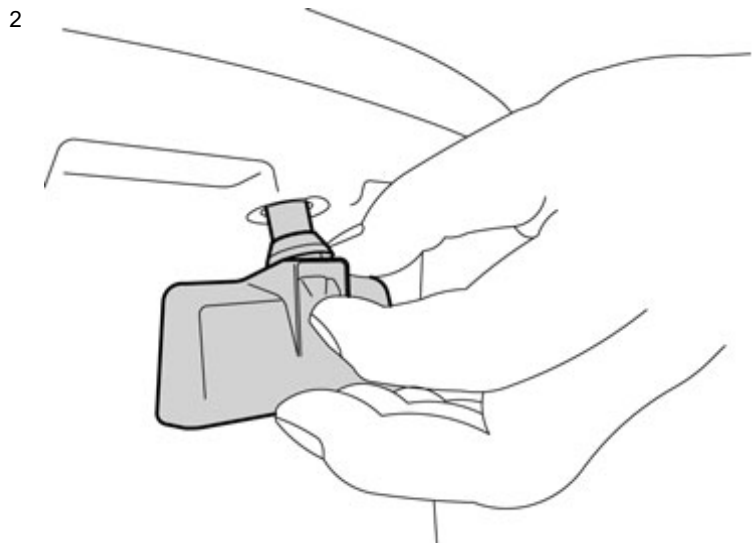

IMG-238180

Install the valve in the valve hole without changing the angle between the valve and sensor body. (Keep the setting that the unit was supplied with).

The laser marking must be visible to the installer.

Installation instructions, accessories

Volvo Car Corporation Gothenburg, Sweden

3

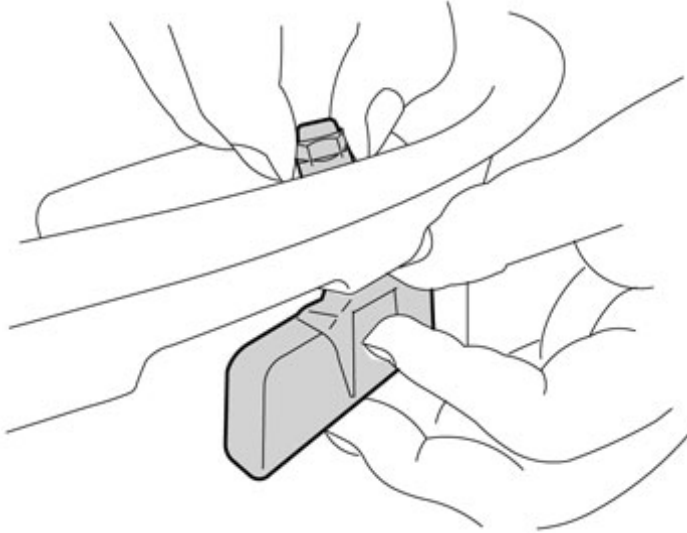

IMG-238181

When the valve is fully inserted in the valve hole, ensure that the sensor body is against the rim, and then start to manually screw the valve's mounting nut a few turns with the other hand.

4

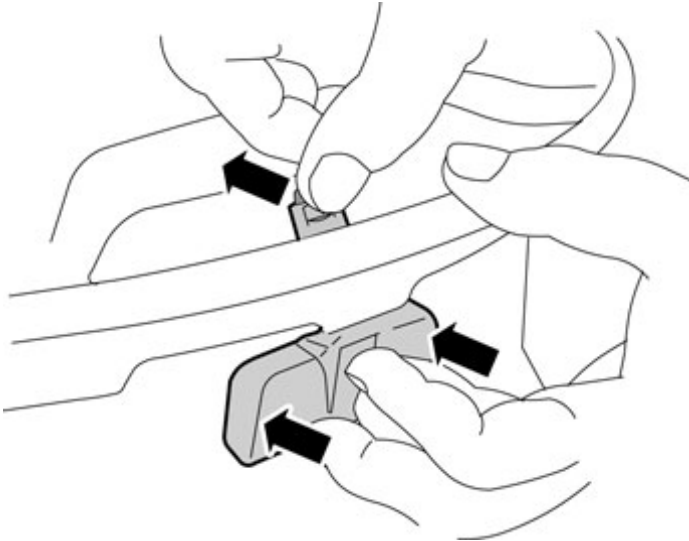

IMG-238182

At the same time as keeping the sensor body against the rim by pressing the rear of the valve with one hand, press the valve's mounting nut carefully towards the centre of the rim with the other hand. This is to obtain the correct angle between valve and sensor body whilst the sensor body is against the rim.

Note!

It is important that the sensor body maintains contact with the rim.

Installation instructions, accessories

Volvo Car Corporation Gothenburg, Sweden

5

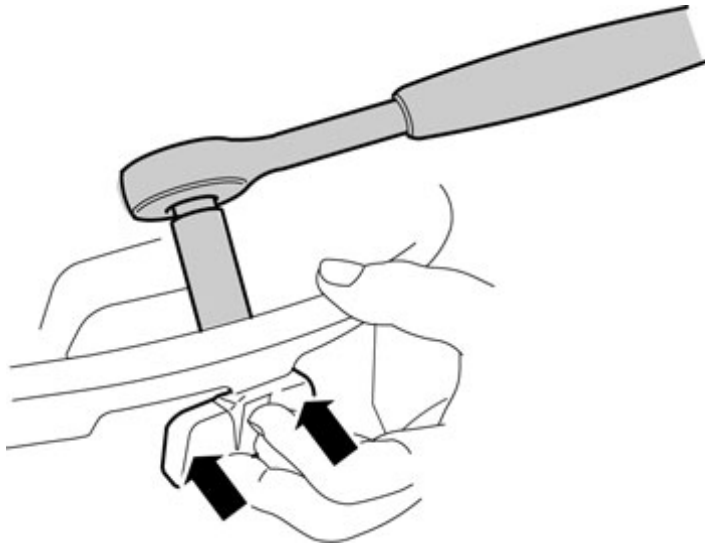

IMG-238183

Whilst holding the sensor body and valve in position with one hand, tighten the valve's mounting nut with the other. Ensure that the socket fits properly on the mounting nut. Torque tighten the mounting nut to **8 Nm (6 lbf.ft.)**.

6

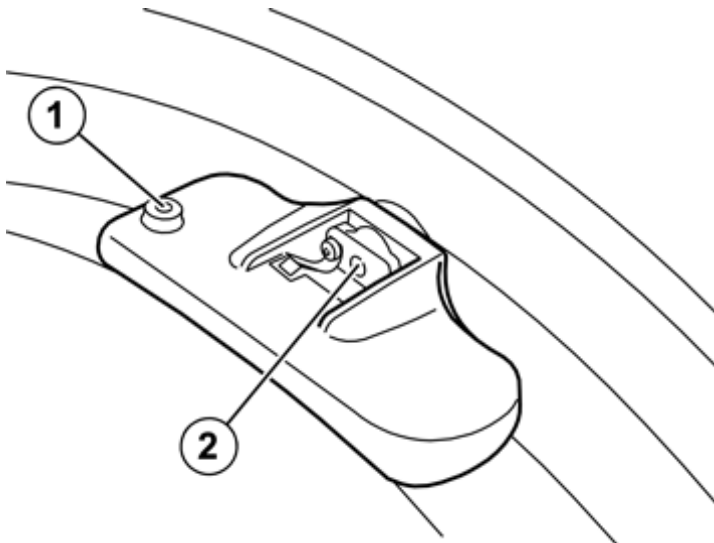

IMG-229209

Caution!

When fitting the tyre on the rim:

Ensure that the sensor is properly attached to the rim before fitting the tyre.

Lubricate the tyre edges with tyre paste to facilitate fitting.

No tyre paste or other foreign particles may cover the hole (1) for filling with air, or the hole (2) for measuring the air pressure on the sensor.

No pressure may be exerted on the sensor when fitting the tyre.

Ensure that the tyre does not get stuck between rim and sensor when fitting.

Do not use installation tools between the sensor and the edge of the tyre.

The tyre must be fitted so that the tyre pressure sensor moves away from the tyre fitting tool.

Installation instructions, accessories

Volvo Car Corporation Gothenburg, Sweden

7

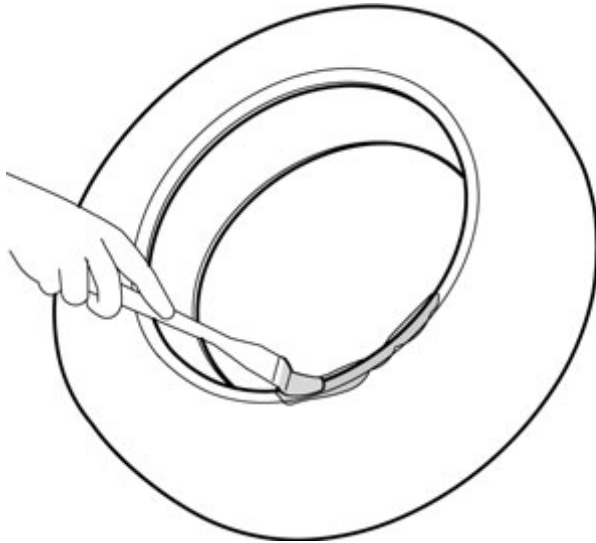

IMG-238184

Fitting tyre onto rim

Place the tyre in the tyre machine and lubricate the tyre edges with tyre paste.

8

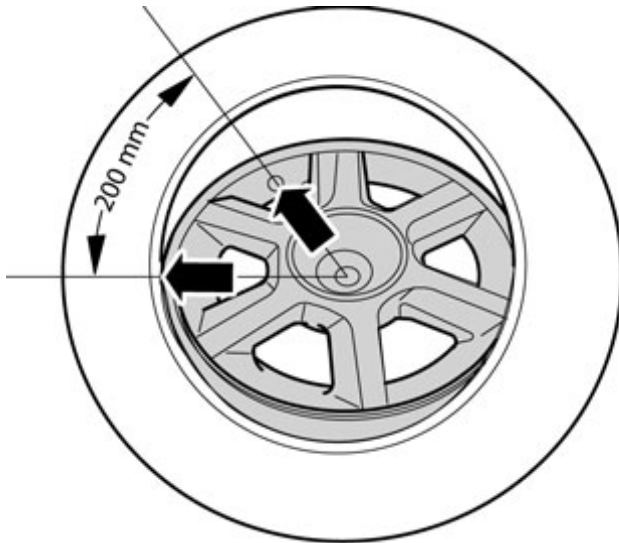

IMG-238185

Fit the tyre onto the rim so that the distance between the valve and where the tyre touches the rim is about 200 mm.

Installation instructions, accessories

Volvo Car Corporation Gothenburg, Sweden

9

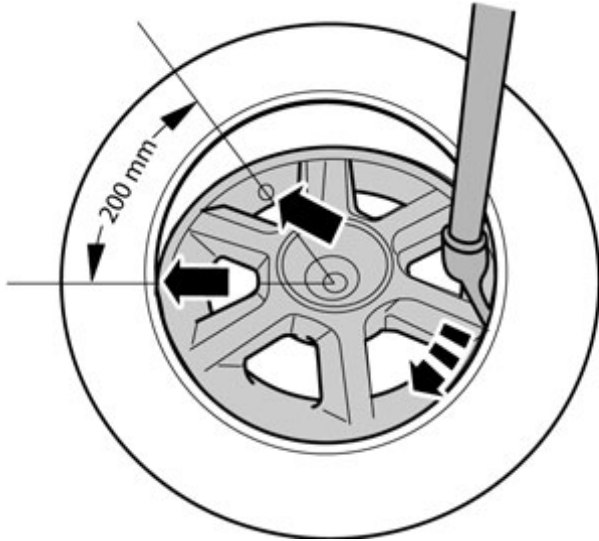

IMG-238186

Install the tyre shoe and ensure that the distance of 200 mm between the valve and the touching point between tyre and rim is maintained. The curved arrow shows the rotation of the wheel.

10

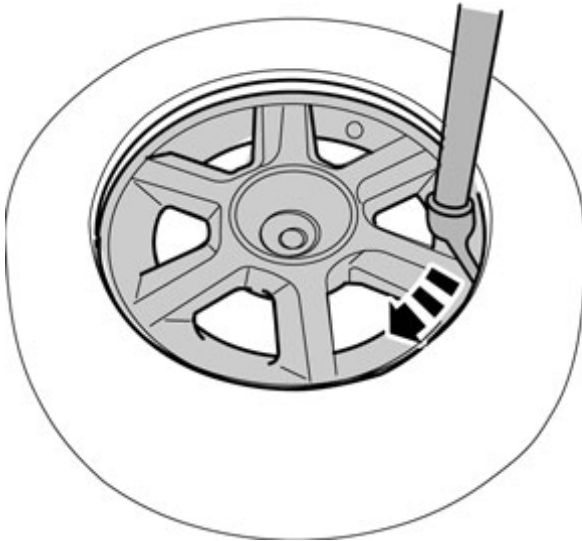

IMG-238187

Turn the wheel to get the tyre's first side into position. The standard shoe can pass over the sensor without damaging it.

Installation instructions, accessories

Volvo Car Corporation Gothenburg, Sweden

11

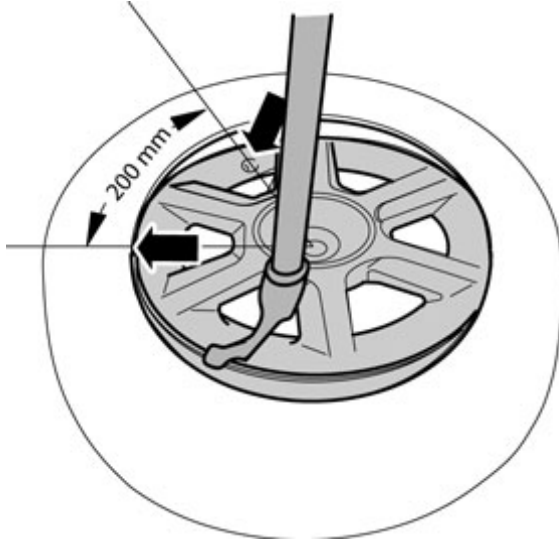

IMG-238188

Position the other side of the tyre so that the distance between the valve and where the tyre touches the rim is about 200 mm. The curved arrow shows the rotation of the wheel.

12

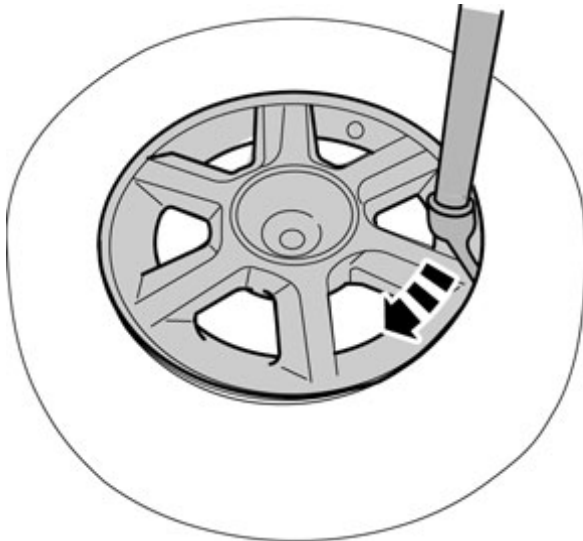

IMG-238189

Turn the wheel to get the tyre's other side into position. The standard shoe can pass over the sensor without damaging it.

13

Fill the tyre with air and balance it after fitting.

Installation instructions, accessories

Volvo Car Corporation Gothenburg, Sweden

14



A0801178

After fitting the wheels on the car

Torque tighten the wheel nuts to **140 Nm (103 lbf.ft)**.

Program the software according to service information in VIDA.

15



IMG-382866

Calibrate the TPMS sensors.

Use special tool: T9513035, TPMS tool