

1. PRODUCT OVERVIEW

We are pleased that you have chosen our SWINGFIX i-SIZE to accompany your child safely through a new stage of his or her life. In order to protect your child correctly, the SWINGFIX i-SIZE must always be used and installed as described in these instructions.

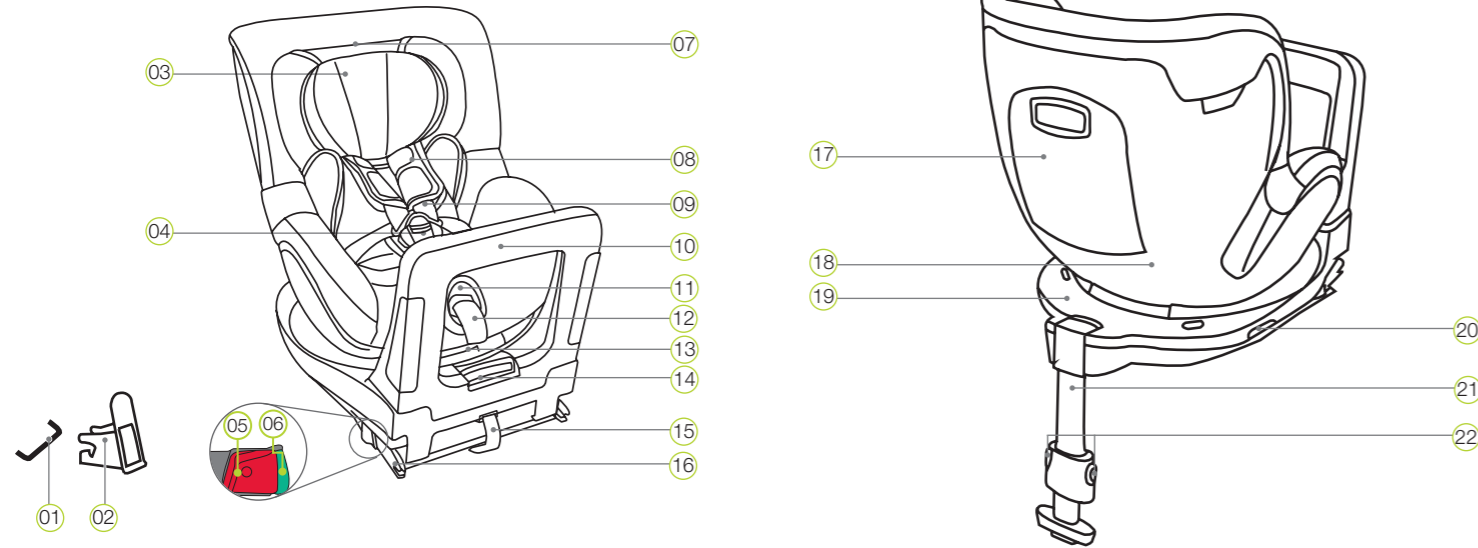

- | | | |
|--------------------------------------|--------------------------------|---------------------------------------|
| 01 ISOFIX fastening points (vehicle) | 09 Shoulder straps | 17 Operating instructions compartment |
| 02 ISOFIX insertion aids | 10 Shock bar | 18 Seat shell |
| 03 Headrest | 11 Adjustment button | 19 Bottom section of shell |
| 04 Harness buckle | 12 Adjustment strap | 20 Rotation button |
| 05 Release button | 13 Tilt adjustment handle | 21 Support leg |
| 06 Safety button | 14 Shock bar adjustment handle | 22 Support leg adjustment buttons |
| 07 Headrest release button | 15 Fabric loop | |
| 08 Shoulder pads | 16 ISOFIX locking arms | |

4. PUTTING THE CHILD IN/TAKING THE CHILD OUT

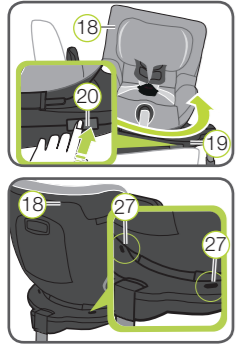

- Press the rotation button (20) on the side of the bottom section (19), rotating the seat shell (18) 90° towards the vehicle door at the same time.
- Now you can put your child in or take him or her out easily.
- Secure your child in the seat (see Section 8. USING THE CHILD SAFETY SEAT).
- Rotate the seat shell (18) 90° until it engages with a clicking sound.
- Make sure that both indicators (27) are black. If one of the indicators is red, the seat shell (18) is not engaged properly.

Caution: Before every journey, make sure that the rotating seat shell (18) is fully engaged and both indicators are black.

- The buckle tongues (29) no longer engage (i.e. when you try to push them in, they pop out again).
- The buckle tongues (29) engage without an audible click.
- The buckle tongues (29) are difficult to push in (you feel a certain amount of resistance).
- The harness buckle (04) only opens if extreme force is applied.

Remedy: Clean the harness buckle (04) so that it functions properly again with no trouble:

Cleaning the harness buckle

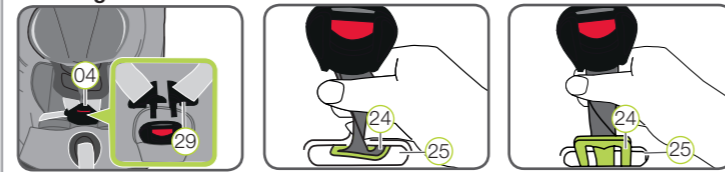

- Remove the cover from the surface of the seat as described below under "Removing the cover".
- Rotate the crotch harness with the metal plate (24) which holds the harness buckle (04) in the seat shell (18) by 90° in the longitudinal slot.
- Slide the metal plate (24) through the harness slot (25) with the narrow edge facing forwards.
- Soak the harness buckle (04) in warm water containing washing-up liquid for at least an hour. Rinse the buckle thoroughly and dry it.
- Slide the metal plate (24) fully into the longitudinal slot from the front.
- Rotate the crotch harness with the metal plate (24) by 90° until it is hooked into the harness slot (25) on the seat shell (18) perpendicular to the direction of motion.

DANGER! Tug hard on the harness buckle (04) to make sure that it is secure in the seat shell (17).

- Thread the harness buckle (04) through the crotch pad (23) on the cover and then re-fasten the Velcro fastener and the cover.

Removing the cover

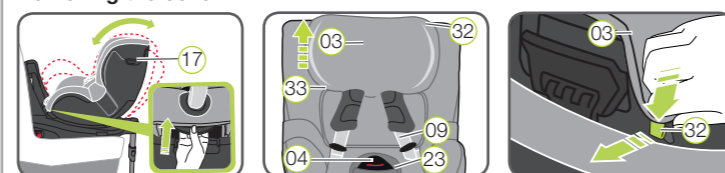

5. CARE AND MAINTENANCE

Cleaning

Only use authentic VOLVO seat covers. The seat cover is an integral part of the child safety seat and is key to ensuring the trouble-free functionality of the system.

- The cover can be removed and washed with a mild detergent on a washing machine's delicates cycle (30 °C). Please observe the instructions on the washing label of the cover.
- The baby insert can be washed in the same way as the cover. Remove all foam parts from the top and bottom sections before washing. These must not be washed.
- The shoulder pads can be removed and washed in lukewarm soapy water.
- The plastic parts and the harnesses can be cleaned with soapy water. Do not use any caustic cleaning agents (such as solvents).

Caring for the harness buckle

To ensure the safety of your child, it is absolutely essential that the harness buckle (04) continues to function correctly. Harness buckle (04) malfunctions are usually caused by a build-up of soiling or by external objects:

- When you press the red release button, it takes a long time for the buckle tongues (29) to be ejected.

2. APPROVAL

These instructions use the following symbols:

Symbol	Keyword	Explanation
⚠	DANGER!	Risk of severe personal injury
⚠	WARNING!	Risk of minor personal injury
⚠	CAUTION!	Risk of material damage
ℹ	TIP!	Useful notes

The SWINGFIX i-SIZE is exclusively intended to secure your child in your vehicle.

BRITAX RÖMER Child safety seat	Tested and approved according to ECE* R 129/02	
	Body size	Body weight
SWINGFIX i-SIZE	40–105 cm	≤ 18 kg

*ECE = European Standard for Child Safety Equipment

The child safety seat has been designed, tested and approved according to the requirements of the European Standard for Child Safety Equipment (ECE R 129/02). The seal of approval "E" (in a circle) and the approval number are located on the orange approval label (sticker on the child safety seat).

DANGER! This certification will be invalidated if you make any modifications to the child safety seat. Only the manufacturer is permitted to make modifications to the child safety seat. Unauthorised technical changes can cause the protective function of the seat to be reduced or completely eliminated. Do not make any technical changes to the child safety seat.

DANGER! Use the SWINGFIX i-SIZE exclusively for securing your child in your vehicle. It is in no way suitable for use as a seat or toy in the home.

- Put the seat shell (17) into its flattest position.
- Loosen the shoulder straps (09) and open the harness buckle (04).
- Slide the headrest (03) into the highest position.
- First unhook the rubber loop (33) at the bottom edge of the headrest (03), followed by the hook (32) at the top edge, and remove the cover.
- Slide the headrest (03) into the lowest position.
- Open the press studs at the left and right on the back of the cover and thread the shoulder straps (09) through the opening.
- Open the Velcro fastener on the crotch pad (23).
- Unhook the rubber loops (33) and the plastic cards from the leg area.
- Unhook the elastic seam of the cover from the bottom.
- Pull the cover from the bottom over the adjustment button (13) by the adjustment strap, over the harness buckle (04) and then over the headrest (03) by the opening.

DANGER! The child safety seat must not be used without the seat cover.

Reattaching the cover:

Proceed in reverse order to put on the cover.

Caution: The harnesses must not be twisted and must be correctly positioned in the harness slots.

Removing the shoulder pads

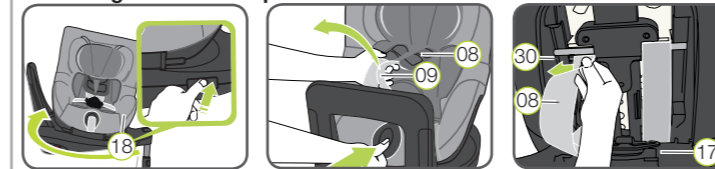

- Rotate the seat shell (18) so it is facing backwards.
- Loosen the shoulder straps (09) as far as possible.
- Open the shoulder pads (08) at the Velcro fasteners at the side.
- Open the operating instructions compartment (17).
- Pull the shoulder straps (09) out a little and unhook the underlying harness loops on the shoulder pads (08) from the plastic fins (30) of the height adjuster.
- Pull the shoulder pads (08) forwards out of the harness slots.

Reattaching the shoulder pads:

Follow the steps for removing the pads in reverse order.

Caution: The shoulder pads (08) and the harnesses must not be twisted or have their places changed over. The shoulder straps (09) must be located under the black cover band in the shoulder pads (08).

3. USE IN THE VEHICLE

Please observe the instructions for using children's restraining systems in the operating instructions of your vehicle. During use, be sure to observe any restrictions relating to airbags.

Please refer to the operating instructions for your vehicle for information about vehicle seats which are certified for the use of children's restraining systems according to ECE R16.

SWINGFIX i-SIZE usage options:

BRITAX RÖMER Child safety seat	Vehicle seating position with ISOFIX	
	i-Size	Not i-Size
SWINGFIX i-SIZE	✓	See type list

You can use your child safety seat as follows:

Facing forwards (in the direction of travel)	No
Facing backwards (against the direction of travel)	Yes ¹⁾
With 2-point or 3-point safety harness	No
On seats featuring: ISOFIX fastenings	Yes ¹⁾

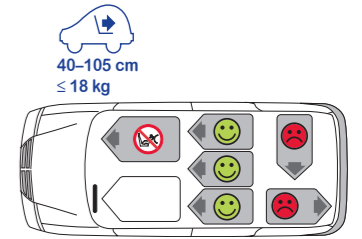

(Please observe the applicable regulations in force in your country)
1) Do not use on passenger seats with an active front airbag!

Contact:

BRITAX RÖMER
Kindersicherheit GmbH
Theodor-Heuss-Straße 9
89340 Leipheim
Germany

T: +49 (0) 8221 3670-199/-299
F: +49 (0) 8221 3670 -210
E: service.de@britax.com
www.britax-roemer.com

BRITAX EXCELSIOR LIMITED
1 Churchill Way West
Andover
Hampshire SP10 3UW
United Kingdom

T: +44 (0) 1264 333343
F: +44 (0) 1264 334146
E: service.uk@britax.com
www.britax-roemer.com

40 - 105 cm
≤ 18 kg

britax

SWINGFIX i-SIZE

GB

Operating instructions



www.britax-roemer.com

6. SAFETY NOTES

⚠ Please take the time to read these instructions carefully and keep them to hand in the intended operating instructions compartment (17) on the child safety seat at all times. The instructions must be kept with the child safety seat if the latter is passed on to a third party. In order for the SWINGFIX i-SIZE to protect your child correctly, it must always be installed and used exactly as described in these instructions. It is possible that some of the child safety seat settings will lead to restrictions when used in "i-Size" vehicle seat positions.

⚠ DANGER! For the protection of your child:

- In the event of an accident with a collision speed of more than 10 km/h, the child safety seat may be damaged without the damage becoming immediately visible. In this case the child safety seat must be replaced. Please dispose of it properly.
- As a rule, have your child safety seat checked if it has been damaged (e.g. if it falls on the ground).
- Regularly check all important parts for damage. Ensure that all mechanical parts, in particular, are fully functional.
- Never lubricate or oil parts of the child safety seat.
- Never leave your child unattended in the child safety seat in the vehicle.
- Only allow your child to enter and exit the vehicle on the pavement side.
- Protect the child safety seat from intensive direct sunlight when it is not in use. The child safety seat can get very hot in direct sunshine. Children's skin is sensitive and could be harmed as a result.
- The more snugly the belt fits over your child's body, the better they will be protected. Therefore, avoid putting thick clothes on your child under the belt.
- Take regular breaks on long journeys in order to give your child the opportunity to run about and play.
- Use on the rear seat: Move the front seat far enough forwards to ensure that your child's feet cannot hit the backrest of the front seat (to prevent the risk of injury).

⚠ DANGER! For the protection of all vehicle occupants:

- In the case of an emergency stop or an accident, unsecured persons or objects may cause injury to other vehicle occupants. Please always check that ...
- no other load-bearing contact points are used other than those specified in these instructions and marked out on the child safety seat.
 - the backrests of the vehicle seats are locked (e.g. that a folding rear seat bench latch is engaged).
 - all heavy or sharp-edged objects in the vehicle (e.g. on the parcel shelf) are secured.
 - all persons in the vehicle have their seatbelts fastened.
 - the child safety seat is always secured when it is in the vehicle, even if no child is being transported.

⚠ WARNING! For your protection when handling the child seat:

- Never use the child safety seat free-standing, not even for test sitting.
- To avoid damage, ensure that the child safety seat is not jammed in between hard objects (vehicle door, seat rails, etc.).
- Keep the child safety seat in a safe place when it is not in use. Do not place any heavy objects on the seat and do not store it directly next to sources of heat or in direct sunlight.

⚠ CAUTION! For the protection of your vehicle:

- Certain vehicle seat covers made from more sensitive materials (e.g. velour, leather) may sustain signs of wear and tear when using child safety seats. For optimum protection of your vehicle seat covers, we recommend using the VOLVO kick guard from our range of accessories.

7. PREPARATORY WORK



1. If your vehicle is not fitted with ISOFIX insertion aids as standard, clamp the two insertion aids (02), which are included in the scope of delivery of the seat*, with the opening pointing upwards, to the two ISOFIX fastening points (01) of your vehicle.
- ⓘ TIP!** The ISOFIX fastening points are located between the surface and the backrest of the vehicle seat.
2. Move the headrest of the vehicle seat into the top position.

* The insertion aids facilitate the installation of the child safety seat with the use of the ISOFIX fastening points and prevent damage to the vehicle seat covers. As long as they are not used, remove them and keep them in a safe place. For vehicles with a folding backrest, the insertion aids need to be removed before folding the backrest. Any problems occurring usually come from soiling or external objects on the insertion aids and on the hook. Remove soiling or external objects to rectify such problems.

8. INSTALLATION OF THE CHILD SAFETY SEAT

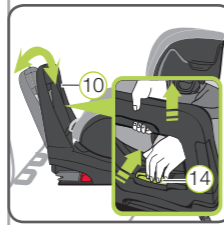

1. ADJUSTING THE SHOCK BAR

- 1.1 Place the child seat facing forwards (in the direction of travel) on a suitable vehicle seat.
- 1.2 Press the adjustment handle (14) on the shock bar (10) down with one hand and use the other hand to pull the shock bar (10) up at the same time, until it unlocks.
- 1.3 Adjust the angle of the shock bar (10) to the angle of your vehicle seat backrest so the shock bar (10) engages with a clicking sound.



2. PREPARING THE ISOFIX

- 2.1 Pull the grey fabric loop (15) until the ISOFIX locking arms (16) are fully extended.
- 2.2 Push the green safety button (06) and the red release button (05) on both sides of the seat towards each other. This ensures that both hooks on the ISOFIX locking arms (16) are open and ready to use.

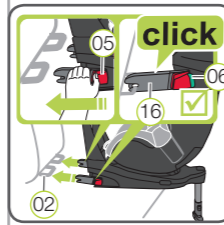

3. FASTENING THE ISOFIX

- 3.1 Position the two ISOFIX locking arms (16) directly in front of the two insertion aids (02).
 - 3.2 Push both ISOFIX locking arms (16) into the insertion aids (02) until the ISOFIX locking arms (16) engage on both sides with a clicking sound.
- ⚠ DANGER!** The green safety button (06) must be visible on both sides so that the child safety seat is correctly fastened.



4. PUSHING THE CHILD SAFETY SEAT ON SECURELY

Push the child safety seat as far as possible towards the vehicle seat backrest.



5. CHECKING THE FASTENING

Shake the child safety seat to ensure that it is securely fastened and check the safety buttons (06) to make sure that the two indicators are fully green.

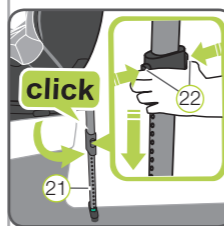

6. INSTALLING THE SUPPORT LEG

- 6.1 Pull the support leg (21) away from the back of the child safety seat until you hear a click and the support leg (21) is fully extended. The red marking must not be visible any more.
 - 6.2 Push both adjustment buttons (22) and pull out the support leg (21) until it rests firmly on the floor of the vehicle. The indicator on the support leg (21) must be fully green and the two adjustment buttons (22) must engage with a clicking sound.
- ⚠ DANGER!** The support leg (21) must never be suspended in mid-air or supported by other objects. Make sure that the support leg (21) does not lift the SWINGFIX i-SIZE bottom section (19) up from the surface of the vehicle seat.



7. TENSIONING THE ADJUSTMENT STRAP

Pull the adjustment strap (12) until the strap lies flat and snug on your child's body.

⚠ WARNING! The hip belt must lie as low as possible over your child's hips.

9. USING THE CHILD SAFETY SEAT

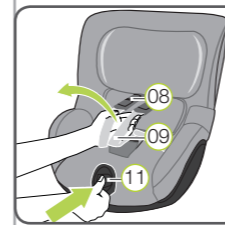

1. LOOSENING THE SHOULDER STRAPS

To loosen the shoulder straps, press the strap adjustment button (11) and, at the same time, pull both shoulder straps (09) forwards.

⚠ CAUTION! Do not pull the shoulder pads (08).

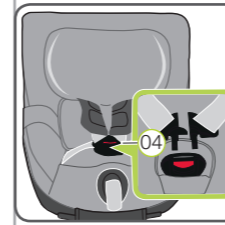

2. OPENING THE HARNESS BUCKLE

To open the harness buckle (04), press the red button on the harness buckle.

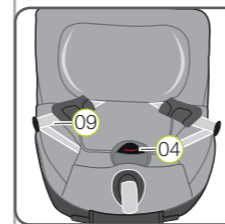

3. POSITIONING A CHILD IN THE SEAT

Place your child in the child safety seat. Make sure that the harness buckle (04) is folded forwards and place your child in the child safety seat.

⚠ DANGER! Only use the child safety seat facing backwards on the passenger seat if the front airbag has been deactivated.

4. FITTING THE SHOULDER STRAPS

Lay the shoulder straps (09) over your child's shoulders.

⚠ CAUTION! The shoulder straps (09) must not be twisted or have their places changed over.

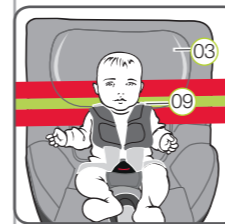

5. ADJUSTING THE HEADREST

A correctly adjusted headrest (03) ensures optimum protection for your child in the child safety seat:

The headrest (03) must be adjusted so that the shoulder straps (09) are at the same level as your child's shoulders or slightly higher.

- ▶ The shoulder straps (09) must be adjusted so that they run horizontally or just above your child's shoulders.
- ▶ The shoulder straps (09) are not allowed to run behind your child's back, or level with/above their ears.

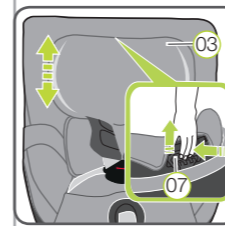

To adjust the headrest:

- 5.1 Loosen the harness (8.1).
- 5.2 Hold the release button (07) on the headrest (03) down and slide the headrest (03) until it is at the correct shoulder strap height.
- 5.3 Check that the headrest (03) is properly engaged by sliding the headrest (03) down a little.

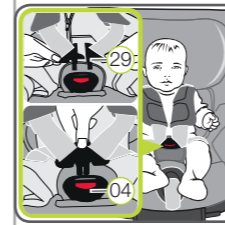

6. CLOSING THE HARNESS BUCKLE

Push the two buckle tongues (29) together and push them into the harness buckle (04) until they engage with a clicking sound.

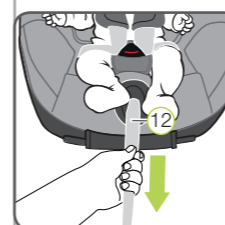

⚠ Before each car journey, in order to ensure your child's safety, make sure that ...

- the child safety seat is fastened in the ISOFIX fastening points (01) on both sides with the ISOFIX locking arms (16) and both ISOFIX indicators (06) are fully green;

- the child safety seat is securely fastened;
- the support leg (21) is resting firmly on the floor of the vehicle and the indicator on the support leg (21) is green;
- the rotating seat shell (18) is fully engaged and both indicators are black;
- the harness of the child safety seat is fitted snugly to the child's body without being constricting;
- the shoulder straps (09) are correctly adjusted and the straps are not twisted;
- the shoulder pads (08) are in the correct position on your child's body;
- the front airbag is deactivated if you are using the child safety seat on the passenger seat;
- the buckle tongues (29) are fastened into the harness buckle (04).

⚠ CAUTION! If your child tries to open the ISOFIX release buttons (05) or the harness buckle (04), stop immediately as soon as possible. Check whether the child safety seat is correctly fastened and ensure that your child is correctly secured. Explain to your child the dangers associated with their actions.

10. USING THE BABY INSERT

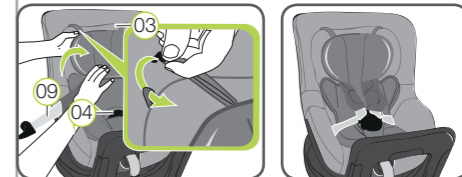

The baby insert must be used up to a maximum body size of 60 cm. Place the baby insert in the child safety seat and lay both shoulder straps (09) over the baby insert. Hook the two plastic hooks into the loops on the cover of the headrest (03). Guide the harness buckle (04) and the crotch pad through the openings in the bottom part of the baby insert.

⚠ CAUTION! Always make sure that your child is properly secured.

11. ADJUSTING THE SEAT ANGLE

The seat shell of the SWINGFIX i-SIZE can be used in six different reclined positions facing backwards:

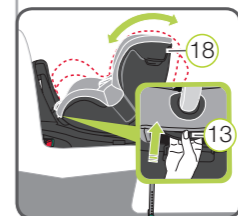

To adjust the seat angle:

Pull the adjustment handle (13) forwards and push/slide the seat shell (18) into the desired position.

⚠ DANGER! The seat shell (18) must engage securely with a clicking sound regardless of its position. Pull up on the seat shell (18) to ensure that it is engaged.

12. REMOVING THE CHILD SAFETY SEAT

1. Press the two adjustment buttons (22) on the support leg and push the bottom part of the support leg into the top part until it is fully inserted. Release the adjustment buttons to fix the support leg in the inserted position.
 2. Loosen the ISOFIX fastening on both sides by pressing the green safety button (06) and the red release button (05) towards each other.
 3. Move the ISOFIX locking arms (16) back into the seat shell (18).
- ⓘ TIP!** The ISOFIX locking arms are protected against damage once they are pushed back into the seat bottom.
- ⚠ DANGER!** The child safety seat must always be secured when it is in the vehicle, even if no child is being transported.

13. DISPOSAL

Please observe the waste disposal regulations in your country.

Disposal of packaging	Container for cardboard boxes
Seat cover	Residual waste, waste incineration
Plastic parts	To be placed in the corresponding container according to labelling
Metal parts	Container for metals
Belt straps	Container for polyester
Buckle and tongue	Residual waste